

D-12 Series

Up to 8 gpm (30 l/min)

D-12 Vertical Applications

The D-12 is specifically designed for vertical pumping installations such as machine tool cooling applications.

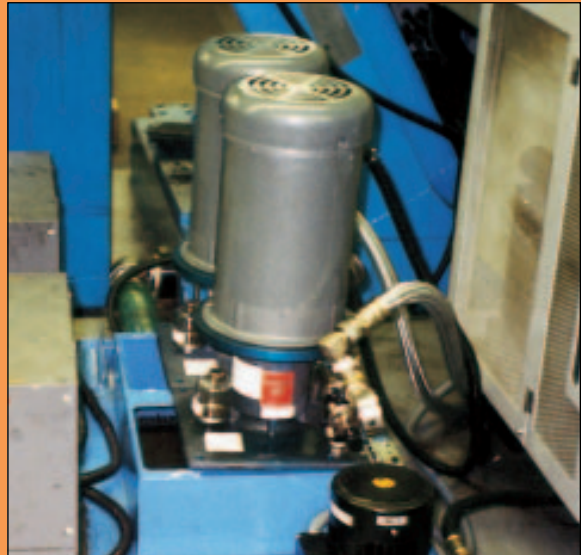

D-12 equipped with
Valve/Tube Accessories
(motor ordered separately)

Hydra-Cell[®]
SIMPLY BUILT TO LAST

D-12 Series Performance

flow

model	max flow		max input
	gpm	l/min	rpm
D-12-X	8	30.3	1450
D-12-E	8	30.3	1750
D-12-S	6	22.7	1750
D-12-I	4	15.1	1750

pressure

Maximum Inlet Pressure:
250 psi (17.3 bar)

Pressure Variable To:
Metallic Heads: 1000 psi (69 bar)

D-12 Pumps accept NEMA motor frames
182/184TC and 213/215TC.

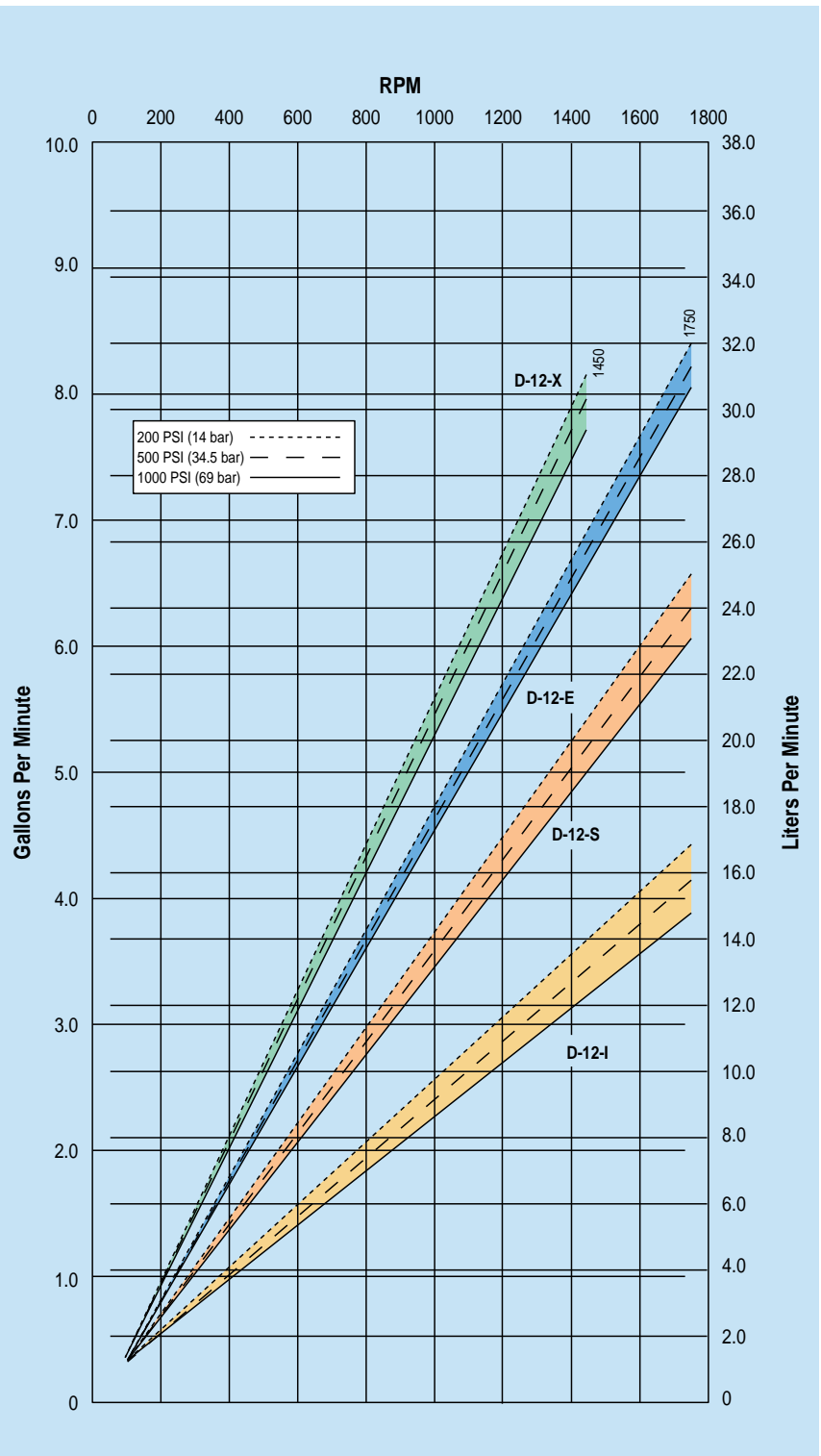

D-12 Series Specifications

Maximum Capacity

	rpm	gpm	l/min
D-12-X	1450	8	30.3
D-12-E	1750	8	30.3
D-12-S	1750	6	22.7
D-12-I	1750	4	15.1

Delivery @ max pressure

	revs/gal	revs/liter
D-12-X	185	49
D-12-E	219	58
D-12-S	292	78
D-12-I	437	115

Max Inlet Pressure 250 psi (17.3 bar)

Pressure Variable to 1000 psi (69 bar)

Max Temperature 250°F (121°C) – Consult factory for correct component selection for temperatures above 160°F (71°C)

Inlet Port 1 inch NPT

Discharge Port 3/4 inch NPT

Shaft Diameter 7/8 inch

Shaft Rotation Bi-directional

Bearings Tapered roller bearings

Oil Capacity 1.5 US quarts (1.4 liters), see page 100 for oil selection and specification.

Weight

Metallic Heads: 63 lbs (28.6 kg)

Calculating Required Horsepower

$$\frac{15 \times \text{rpm}}{63,000} + \frac{\text{gpm} \times \text{psi}}{1,460} = \text{electric motor HP}$$

For installation guidelines and other pump selection design considerations, refer to pages 107-111.

Net Positive Suction Head (NPSHr)

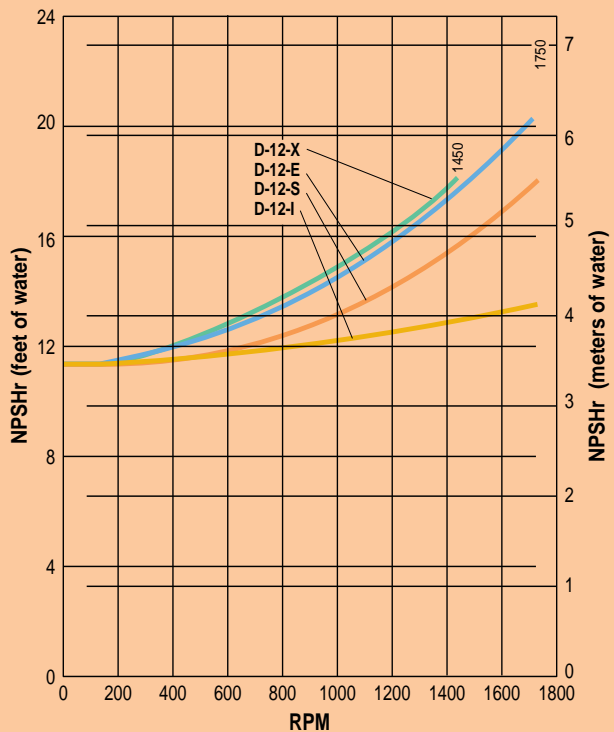

Dry Lift

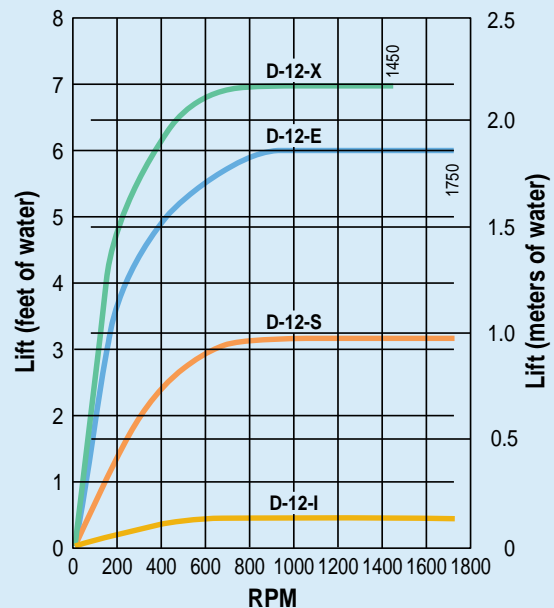

D-12 Series Dimensions

D-12 Standard Configuration

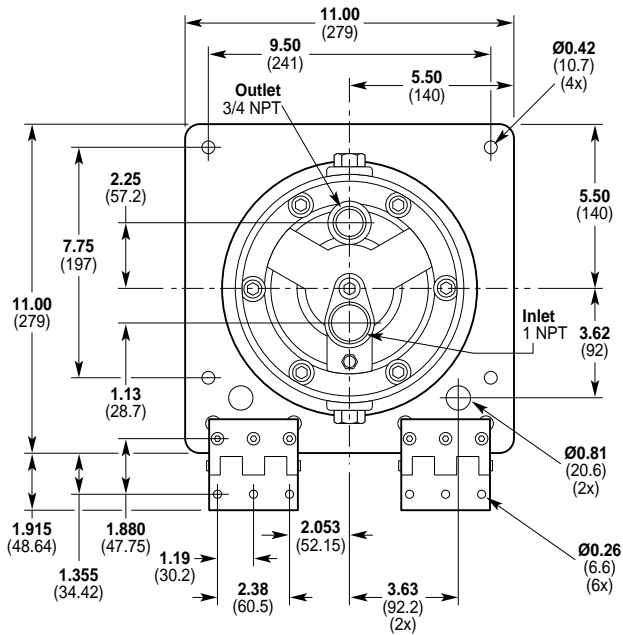
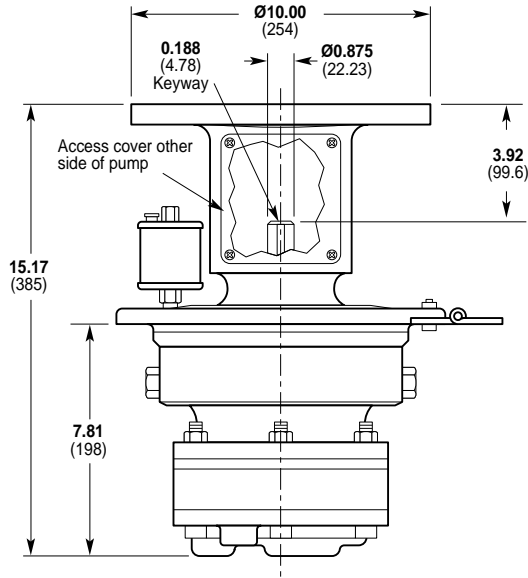

Bottom View (inside tank)

D-12 Series Dimensions

D-12 Models Minimum Tank Size and Critical Installation Dimensions

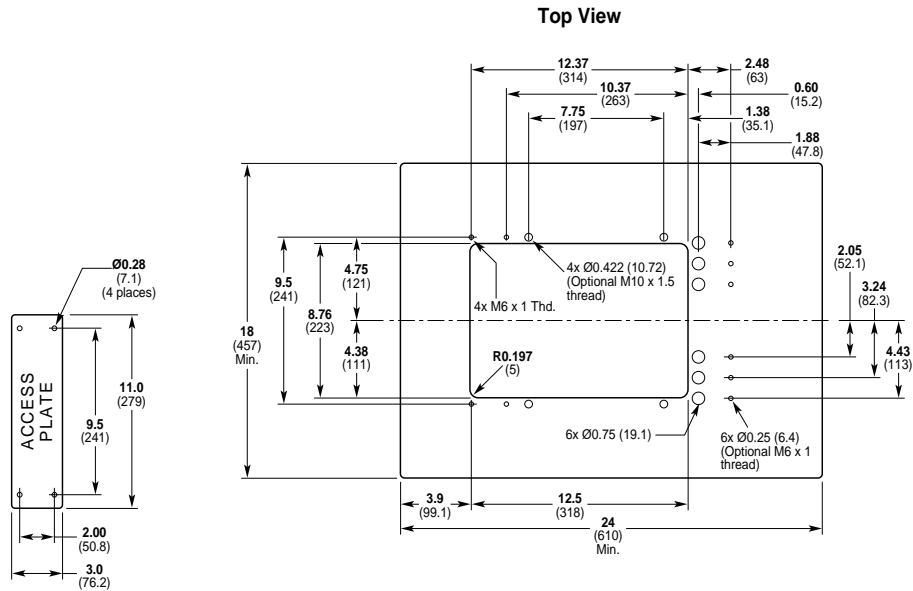

Top of tank must support weight of 200 pounds for pump/motor

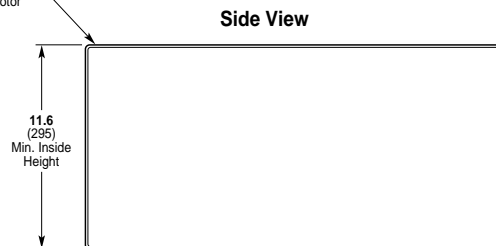

D-12 Series Options

Materials of Construction

D-12 Hydra-Cell pumps are manufactured in a variety of heavy-duty materials to meet specific pumping needs. Refer to the design section for more information on appropriate material selection and chemical compatibility. Other customized materials are available by special order. Contact factory application engineering department for further information.



Pumping Head
316 Stainless Steel
Brass
Cast Iron (nickel plated)



Valves
17-7 PH Stainless Steel
Ceramic
Hastelloy® C
Nitronic 50
Tungsten Carbide



Diaphragms & O-rings
Buna-N-XS
EPDM
Neoprene
Teflon®
Viton®-XT



Valve Springs
Elgiloy®
Hastelloy® C



Valve Seats
17-4 PH Stainless Steel
316 Stainless Steel
Ceramic
Hastelloy® C
Tungsten Carbide



Valve Spring Retainers
17-7 PH Stainless Steel
316 Stainless Steel
Celcon®
Hastelloy® C
Kynar®
Nylon (Zytel®)
Polypropylene

D-12 Series Accessories

Options, Accessories and Custom Designs

- Valves, page 84
- Couplings, page 95
- Hose Connectors, page 99
- Hydra-Oil, page 100
- Oil Cooler and Filtering System, page 102
- Tool Kits, page 105



Valve/Tube Accessories

The D-12 Hydra-Cell Tube and Valve/Tube Accessories provide a pre-fabricated plumbing package for simplified installation. (See page 56 for dimensions.)

Ordering Information

Tube Accessory **A04-007-1200**

Valve/Tube Accessory **A04-008-1200**

(Note: C-22 valve ordered separately, see page 86 for specifications and ordering information.)



D-12 Series How To Order

Ordering Information

A complete D-12 Series Model Number contains 12 digits of customer-specified design options: for example D12XLBNHFCA.



Digit	Order Code	Description
1-3		Pump Configuration*
	D12	Flanged for NEMA 182/184TC, 213/215TC *Tube Accessory Kits ordered separately. See accessories section for selection and pricing information.
4		Hydraulic End Cam
	X	Max 6.2 gpm (23.5 lpm) @ 1150 rpm
	E	Max 8 gpm (30.3 lpm) @ 1750 rpm
	S	Max 6 gpm (22.7 lpm) @ 1750 rpm
	I	Max 4 gpm (15.1 lpm) @ 1750 rpm
5		Pump Head Version
	L	Version L Pump Head
6		Pump Head Material
	B	Brass
	C	Cast Iron (nickel plated)
	S	316 Stainless Steel
7		Diaphragm & O-ring Material
	E	EPDM (requires EPDM-compatible oil – Digit 12 oil code C or D)
	G	Viton®-XT
	J	Teflon®(available with E and S cams only; 1200 rpm max; cannot be used with non-metallic heads)
	P	Neoprene
	T	Buna-N-XS
8		Valve Seat Material
	C	Ceramic
	D	Tungsten Carbide
	H	17-4 PH Stainless Steel
	S	316 Stainless Steel
	T	Hastelloy® C
9		Valve Material
	C	Ceramic
	D	Tungsten Carbide
	F	17-7 PH Stainless Steel – Machined
	N	Nitronic 50
	T	Hastelloy® C

Digit	Order Code	Description
10		Valve Springs
	E	Elgiloy®
	T	Hastelloy® C
11		Valve Spring Retainers
	C	Celcon
	H	17-7 PH Stainless Steel
	M	Kynar®
	P	Polypropylene
	S	316 Stainless Steel
	T	Hastelloy® C
	Y	Nylon (Zytel)
12		Hydra-Oil
	A	10W30 standard duty oil
	B	40-wt for continuous duty (use with 316 SST or Hastelloy® pump head (standard))
	C	30-wt EPDM-compatible oil
	D	40-wt high-temp EPDM-compatible oil
	E	30-wt food-contact oil
	F	40-wt high-temp food-contact oil
	G	5W30 cold-temp severe duty oil
	H	15W50 high-temp severe duty synthetic oil

Replacement Hydraulic End Assembly

Complete D-12 Hydraulic End Assemblies are available as replacement items. The Hydraulic End contains all drive end components from the drive shaft up to and including the diaphragms. All Hydraulic Ends are factory tested and shipped with oil. To order a Replacement Hydraulic End, specify the desired Cam (Digit 4), the Diaphragm and O-ring Material (Digit 7), and the Hydra-Oil (Digit 12).

Part Number*

D12 4* **XX** 7* **XXXX** 12*

* Order Code Digits 4, 7 and 12 must be filled in when ordering.