

EPM

ELECTRONIC PRECISION METERING

P200 Metering Pump

Installation & Service

P200-991-2400A

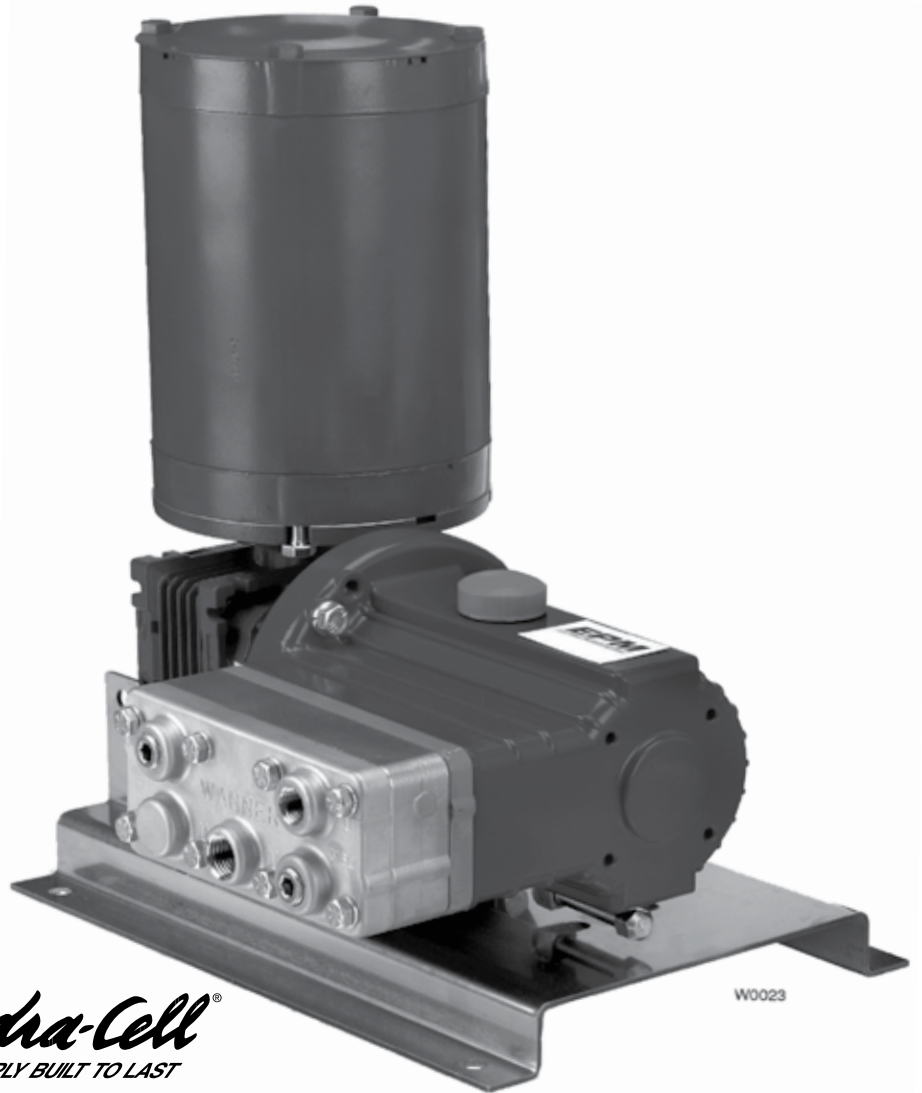

Hydra-Cell[®]
SIMPLY BUILT TO LAST

WANNER ENGINEERING, INC.

Metallic Pump shown (Motor Optional)

1204 Chestnut Avenue, Minneapolis, MN 55403
TEL: (612) 332-5681 FAX: (612) 332-6937
TOLL-FREE FAX [US only]: (800) 332-6812

www.epmpump.com
email: sales@wannereng.com

P200 Contents

	Page
Specifications.....	2
Dimensions	4
Installation.....	5
Maintenance.....	7
Fluid End	
Service	8
Parts List	10
Hydraulic End Parts List	12
Reducer/Base Parts List.....	13
Troubleshooting.....	14
Replacement Parts Kits	15

Component Identification

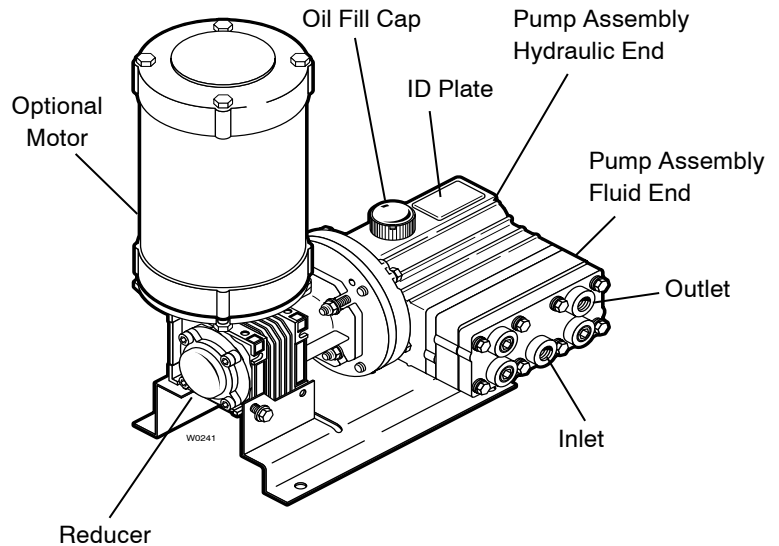

P200 Specifications

Steady State

Accuracy ±1%

Max Pressure

Metallic Head: 1000 psi (70 bar)
 Non-Metallic Head: Polypropylene: 250 psi (17 bar)
 Kynar: 350 psi (24 bar)

Capacity @ 100 PSI (7 bar) Discharge Pressure*

RPM	GPH	LPH
120	13.0	49.2
240	26.0	98.4
360	39.0	147.7
480	52.0	196.9
720	81.0	306.7

Max Inlet Pressure 250 psi (17 bar)

Max Temperature

Metallic Head: 250°F (121°C) – consult factory for temperatures above 160°F (71°C)
 Non-Metallic Head: 140°F (60°C)

Inlet Port 1/2 inch NPT, BSPT

Discharge Port 3/8 inch NPT, BSPT

Shaft Rotation Bi-directional

Oil Capacity 1 US quart (0.95 liters)

Weight

Metallic Head: 39 lbs (17.7 kg)
 Non-Metallic Head: 30 lbs (13.6 kg)

* Capacity data for pumps with elastomeric diaphragms. Consult factory for performance characteristics of pumps with PTFE diaphragms.

Motor Horsepower (kW)*

RPM	1/4 (0.18)	1/4 (0.18)	1/4 (0.18)	1/4 (0.18)
120	1/4 (0.18)	1/4 (0.18)	1/4 (0.18)	1/4 (0.18)
240	1/4 (0.18)	1/4 (0.18)	1/4 (0.18)	1/2 (0.37)
360	1/4 (0.18)	1/4 (0.18)	1/4 (0.18)	1/2 (0.37)
480	1/4 (0.18)	1/4 (0.18)	1/2 (0.37)	3/4 (0.55)
720	1/4 (0.18)	1/2 (0.37)	3/4 (0.55)	1 (0.75)
P#	≤100 (7)	≤250 (17)	≤500 (35)	≤1000 (70)

* This chart is approximate. Contact Wanner Engineering to determine specific motor horsepower application requirements.

P = pressure in PSI (bar)

P200 Specifications

Capacity @ 120 RPM (max)*

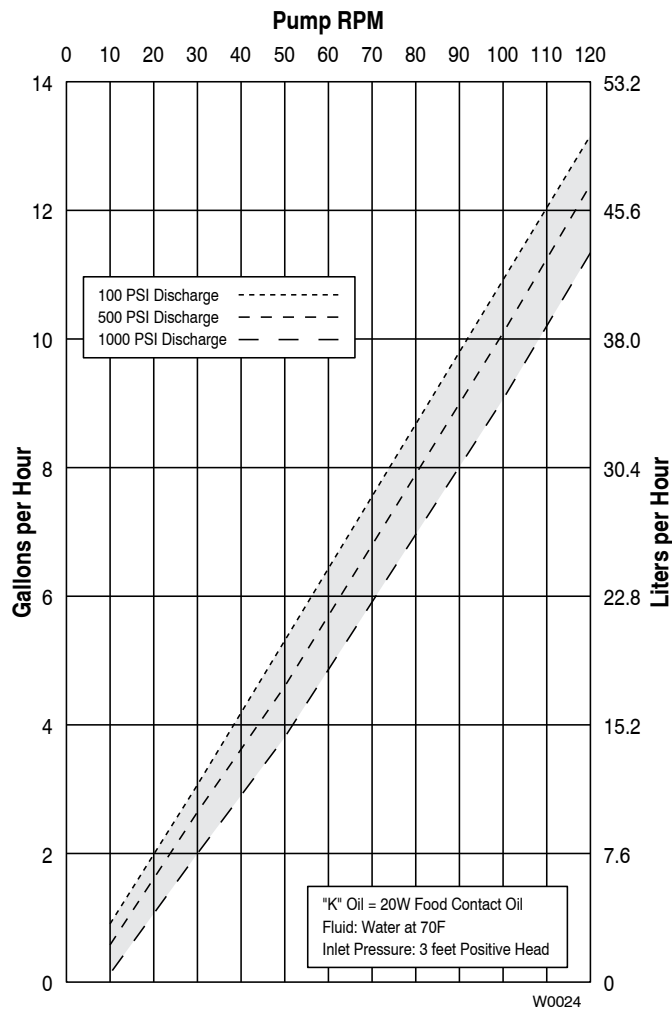

Capacity @ 720 RPM (max)*

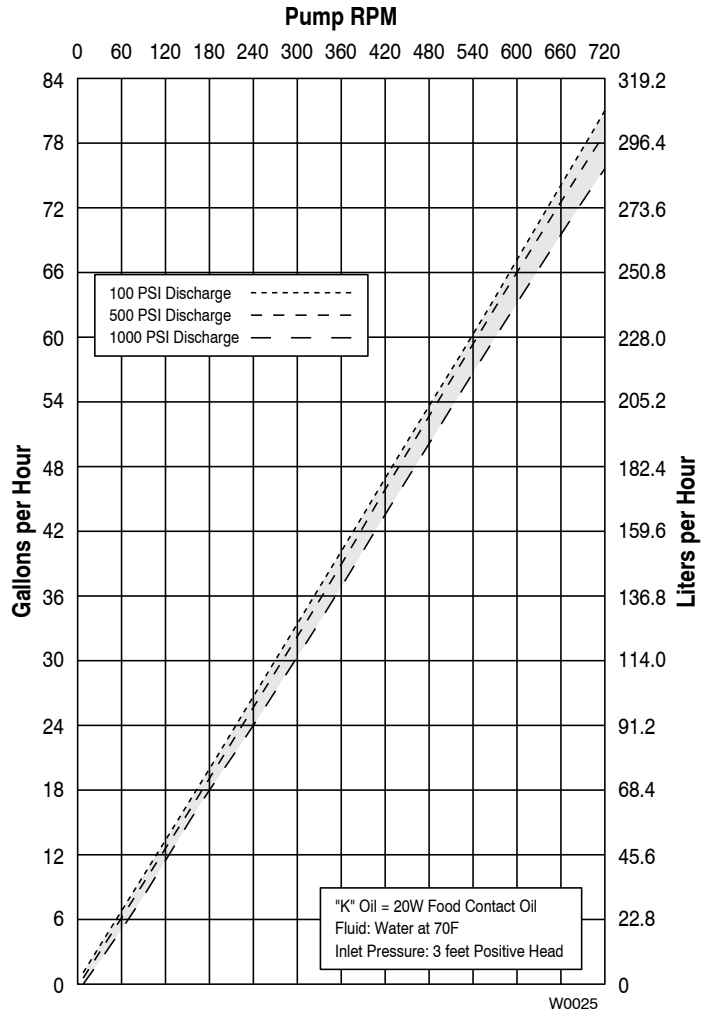

* Capacity data for pumps with elastomeric diaphragms. Consult factory for performance characteristics of pumps with PTFE diaphragms.

Repeatability ^(1,2): ±3% of rated capacity over 10:1 turndown ratio.

Linearity ^(1,2): ±3% of rated capacity over 10:1 turndown ratio.

⁽¹⁾ Required pump discharge pressure equals 50 PSI (3.5 bar) minimum.

⁽²⁾ Requires steady state discharge pressure.

P200 Dimensions

P200 Models with Metallic Pumping Head

Inches (mm)

316 Stainless Steel

Hastelloy® C

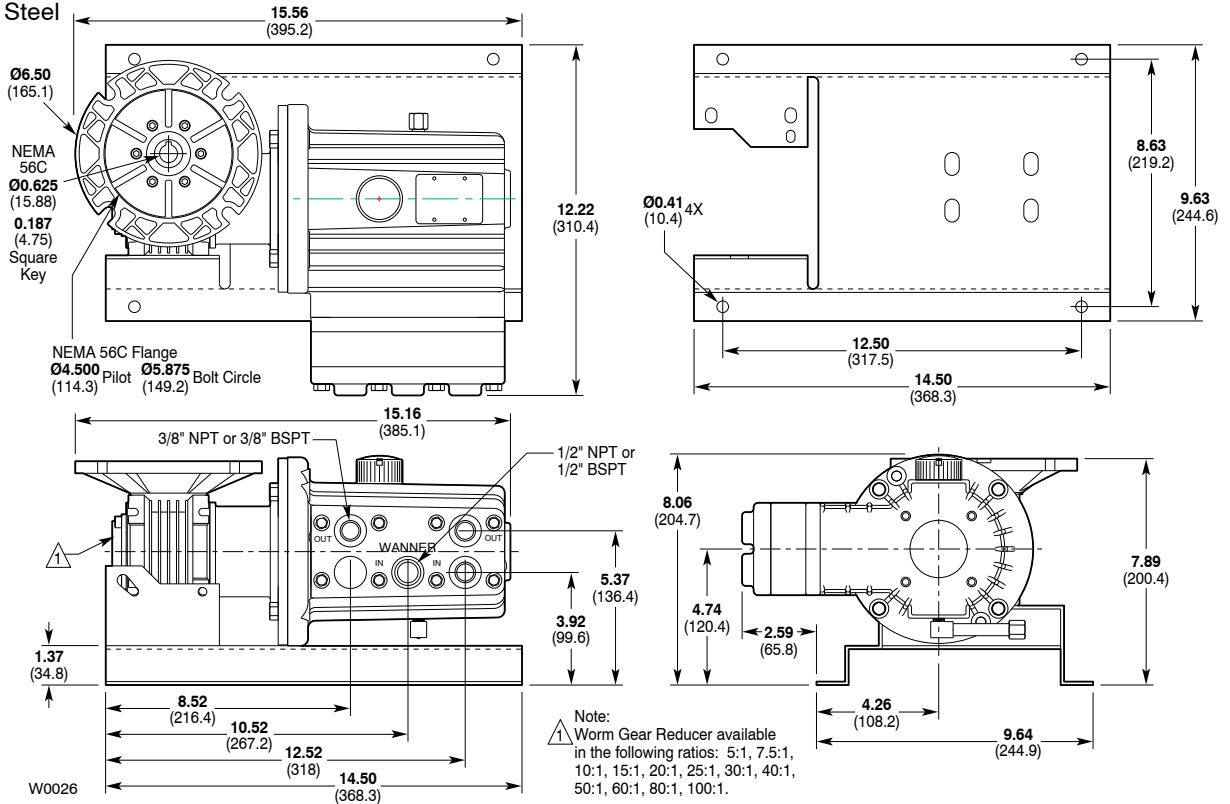

P200 Models with Non-Metallic Pump Head

Kynar

Polypropylene

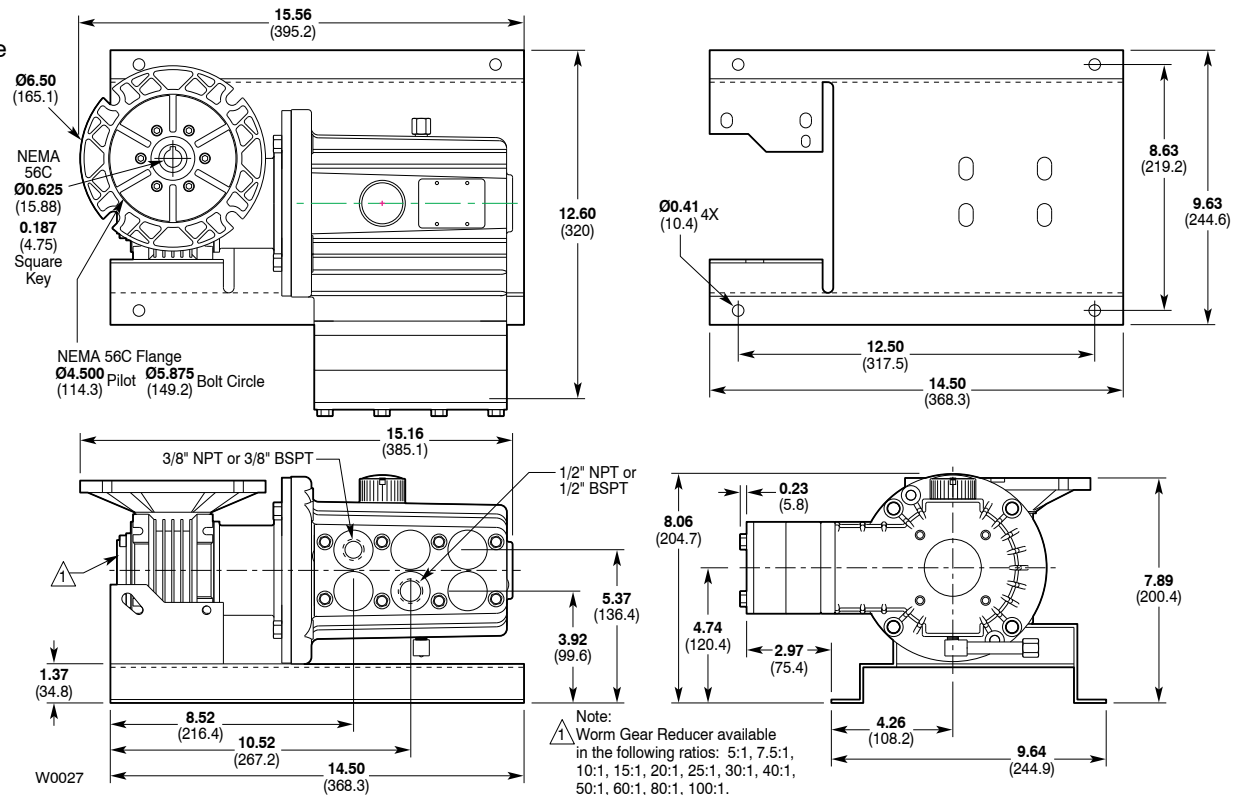

P200 Installation

Location

NOTE: The numbers in parentheses are Reference Numbers located in the Parts List exploded views of this manual.

Locate the pump as close to the supply source as possible.

Install it in a lighted clean space where it will be easy to inspect and maintain.

Motor and Controller

The P Series pump shaft can rotate in either direction, therefore direction of motor shaft rotation is not critical.

Accessories

Consult installation drawing below for typical precision metering fluid system components. Contact Wanner Engineering or the distributor in your area for more details.

Important Precautions

Adequate Fluid Supply. To avoid cavitation and premature pump failure, be sure that the pump will have an adequate fluid supply and that the inlet line will not be obstructed. See **Inlet Piping** on page 6.

Positive Displacement. This is a positive-displacement pump. To avoid severe system damage if the discharge line ever becomes blocked, install a relief valve downstream from the pump. See **Discharge Piping** on page 6.

Safety Guards. Follow all codes and regulations regarding installation and operation of the pumping system.

Shut-Off Valves. Never install shut-off valves between the pump and discharge pressure regulator, or in the regulator bypass line.

Consult the Factory for the following situations:

- Extreme temperature applications (above 160°F or below 40°F)
- Pressure feeding of pumps
- Viscous or abrasive fluid applications
- Chemical compatibility problems
- Hot ambient temperatures (above 110°F)

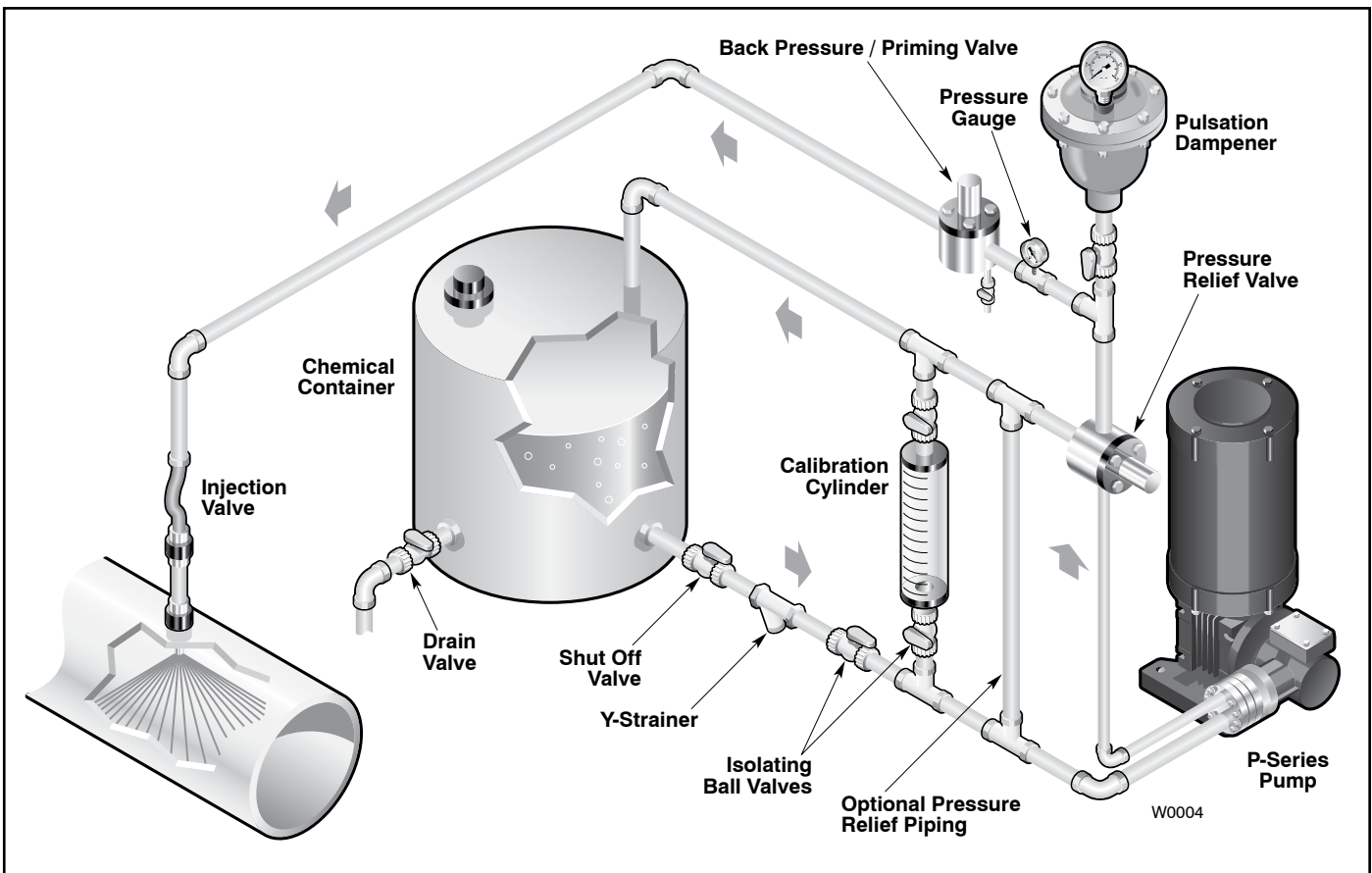

P200 Installation

Inlet Piping

Provide for permanent or temporary installation of a compound pressure gauge to monitor the inlet pressure. To maintain maximum flow, the pump inlet should be under flooded suction conditions at all times. **Do not supply more than one pump from the same inlet line.**

Supply Tank

Use a supply tank that is large enough to provide time for any trapped air in the fluid to escape. The tank size should be at least twice the maximum pump flow rate.

Install a separate inlet line from the supply tank to each pump.

Place a cover over the supply tank, to prevent foreign objects from falling into it.

Hose Sizing and Routing

To minimize acceleration head and frictional losses, size the suction line at least one size larger than the pump inlet, and keep the suction line as short and direct as possible.

Recommendations:

- Keep inlet lines less than 3 ft. (1 m) long
- Use at least 5/8" (16 mm) I.D. inlet hose
- Minimize fittings (elbows, valves, tees, etc.)

Inlet Piping (Pressure Feed)

Provide for permanent or temporary installation of a pressure gauge to monitor the inlet pressure. Pressure at the pump inlet should not exceed 250 psi (17.3 bar); if it could get higher, install a pressure reducing valve. **Do not supply more than one pump from the same inlet line.**

Note: System back pressure must exceed the pump inlet pressure by at least 15 psi (1 bar) in order to prevent flow thru.

Discharge Piping

Hose and Routing

Use the shortest, most-direct route for the discharge line.

Select pipe or hose with a **working pressure** rating of at least 1.5 times the maximum system pressure. EXAMPLE: Select a 1500 psi (103 bar) W.P.-rated hose for systems to be operated at 1000 psi (69 bar) gauge pressure.

Support the pump and piping independently.

Pressure Regulation

Install a pressure relief valve in the discharge line. Bypass pressure must not exceed the pressure limit of the pump.

Size the valve so that, when fully open, it will be large enough to relieve the full capacity of the pump without over-pressurizing the system.

Locate the valve as close to the pump as possible and ahead of any other valves.

Adjust the pressure relief valve to no more than 10% over the maximum working pressure of the system. Do not exceed the manufacturer's pressure rating for the pump or valve.

Route the bypass line to the supply tank.

CAUTION: Never install shutoff valves in the bypass line or between the pump and pressure regulator or relief valve.

Provide for permanent or temporary installation of a pressure gauge to monitor the discharge pressure at the pump.

Minimum Discharge Pressure

To ensure proper capacity control, a minimum discharge pressure of 50 psi (3.5 bar) is required.

P200 Installation

Initial Start-Up Procedure

Before you start the pump, be sure that:

- All shut-off valves are open, and the pump has an adequate supply of fluid.
 - All connections are tight.
 - The oil level is 3/4 in. (20 mm) from the top of the fill port.
1. Open the priming valve on the system back pressure valve so the pump starts under minimum pressure.
 2. Turn on power to the pump motor.
 3. Check the inlet pressure or vacuum. To maintain maximum flow, the pump inlet should be under flooded suction conditions at all times. Inlet pressure must not exceed 250 psi (17.3 bar).
 4. Listen for any erratic noise and look for unsteady flow.
 - Jog the pump on and off until fluid coming from the priming valve is air-free.
 - Close the priming valve.

Calibration Procedure

Each individual metering pump put into service must be calibrated in order to accurately determine required pump speed to achieve the desired flow. The capacity curves shown on page 3 represent a typical pump; individual pumps may vary slightly from these curves. In order to achieve the best possible results, perform calibration under actual process conditions. Follow these steps:

1. Run the pump for 20 minutes at actual process conditions. If the process system cannot be used, circulate back to the supply tank through a pressure relief valve (see Installation drawing on page 5). If required system pressure is less than 50 PSI (3.5 bar) a back pressure valve must be installed and set to produce a minimum of 50 PSI (3.5 bar) pressure at the pump head.
2. Determine maximum pump speed required for all system conditions that need to be satisfied. Measure pump delivery at this maximum speed using your system calibration cylinder, flow meter, or some other means. This is considered to be the "rated capacity" for your particular metering pump.
3. Measure pump delivery at 75%, 50%, 25%, and 10% of the maximum speed just determined. Let the pump run for 5 minutes at each speed setting before taking the capacity measurement.
4. Plot these values on linear graph paper using the horizontal axis for RPM and the vertical axis for GPH, or any other unit of measure you may be using for capacity.
5. Draw a best-fit straight line through the points just plotted. For stable conditions, this line predicts pump speed required to achieve desired flow over a 10:1 turndown ratio.

Note: as pump discharge pressure increases, capacity decreases slightly (see Capacity curves on page 3). For any metering pump there are a series of valid capacity curves that may apply. Use the curve that depends on actual pump discharge pressure and other system conditions. It is critically important to develop a custom capacity curve for each pump and each system.

P200 Maintenance

NOTE: The numbers in parentheses are Reference Numbers located in the Parts List exploded views of this manual.

Periodically

Change the oil according to the guidelines below. When changing, remove the drain plug (60), Allow all oil and contaminant to drain out. Catch the oil and dispose of it properly.

Hours Between Oil Changes @ Various Process Fluid Temperatures

Pressure	<90°F (32°C)	<139°F (60°C)	<180°F (82°C)
Metallic Pump Head			
<800 psi (55 bar)	8,000	5,000	3,000
<1200 psi (83 bar)	4,000	3,000	2,000
Non-Metallic Pump Head			
<250 psi (17 bar)	4,000	3,000	—

NOTE: Minimum oil viscosity for proper hydraulic end lubrication is 16-20 cST (80-100 SSU).

CAUTION: Do not turn the drive shaft while the oil reservoir is empty.

Use the appropriate Hydra-Oil for the application.

Note: P Series replacement parts kits (complete kits and diaphragm kits) include the appropriate oil for each specific P Series pump configuration.

CAUTION: If you are losing oil but don't see any external leakage, or if the oil becomes discolored and contaminated, the diaphragm (17) may be damaged. Refer to the Fluid-End Service Section. Do not operate the pump with a damaged diaphragm.

CAUTION: Do not leave contaminated oil in the pump housing or leave the housing empty. Remove contaminated oil. Dispose of properly. Replace with clean oil.

Check the inlet pressure periodically with a gauge.

P200 Fluid End Service

NOTE: The reference numbers in parentheses are shown in the Fluid End Parts List.

This section explains how to disassemble and inspect all easily-serviceable parts of the pump.

Caution: Do not disassemble the hydraulic end of the pump. Contact Wanner Engineering (Tel 612-332-5681 or Fax 612-332-6937) or the distributor in your area.

1. Remove Manifold (3), Valve Plate (12)

- a. Remove eight bolts (1) around manifold (3).
- b. Remove manifold (3).
- c. Inspect manifold (3) for warping or wear around inlet and outlet ports. If wear is excessive, replace manifold.
To check if manifold is warped, remove o-rings (4) and place straightedge across it. If warped replace.
- d. Remove two socket-head capscrews (14).
- e. Inspect the valve plate (12) as in step c. Replace if necessary.

2. Inspect Valves (5-11)

The three inlet and three outlet valve assemblies are identical and face opposite directions. Inspect each valve as follows:

- a. Check spring retainer (10), and replace if worn.
- b. Check valve spring (8). If shorter than new spring, replace (do not stretch old spring).
- c. Check valve (7). If worn excessively, replace.
- d. Remove valve seat (6) and o-ring (5). A seat puller is included in Wanner Tool Kit.

Inspect valve seat for wear, and replace if necessary. A new o-ring should be installed.

- e. Check the dampening washer (11), and replace if worn.
- f. Reinstall inlet and outlet valve assemblies:

- Clean valve ports and shoulders with emery cloth, and lubricate with lubricating gel or petroleum jelly.

- Install o-ring (5) on valve seat (6).

- **Inlet Valves** (3 lower valves in illustration below). Insert spring retainer (10) into valve plate (12). Then insert spring (8), valve (7), Tetra seal (9), valve seat (6), and dampening washer (11). A flat Tetra seal o-ring (9) goes between spring retainer (10) and valve seat (6) when plastic retainer is used.

- **Outlet Valves** (3 upper valves in the illustration). Insert dampening washer (11), valve seat (6), Tetra seal (9), valve (7), spring (8), and spring retainer (10). Install flat Tetra seal o-ring (9) between spring retainer (10) and valve seat (6) when plastic retainer is used.

INSTALLING INLET AND OUTLET VALVES

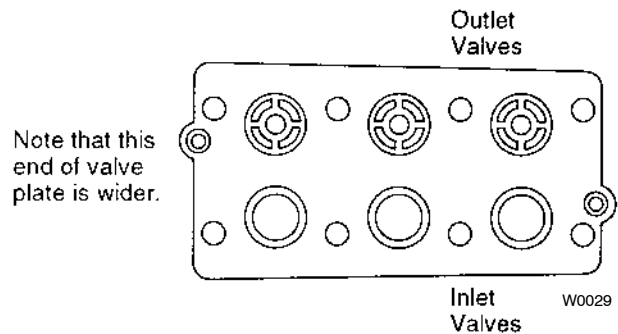

P200 Fluid End Service

3. Inspect and Replace Diaphragms (17)

- a. Lift diaphragm (17) by one edge, and turn pump shaft (**use the shaft rotator from the Wanner Tool Kit**) until diaphragm moves up to “top dead center”. This will expose machined cross holes in plunger shaft behind diaphragm.
- b. Insert hex wrench through one of the machined cross holes, to hold diaphragm (17) up. The proper size tool is included in the Wanner Tool Kit. (Don't remove tool until new diaphragm is installed in step f below.)
- c. Unscrew diaphragm (17). Use 5/16 in. (8 mm) open-end wrench, and turn counterclockwise.
- d. Inspect diaphragm (17) carefully. A damaged diaphragm generally indicates a pumping system problem. Replacing diaphragm only, will not solve the larger problem. Inspect diaphragm for following:
 - **Small puncture.** Usually caused by sharp foreign object in fluid.
 - **Diaphragm pulled away** from sides. Usually caused by fluid being frozen in pump, or by over-pressurization of pump.
 - **Diaphragm becoming stiff** and losing flexibility. Usually caused by pumping fluid that is incompatible with diaphragm material.
 - **Diaphragm edge chewed away.** Usually caused by over-pressurizing system.

Caution: If a diaphragm has ruptured and foreign material or water has entered the oil reservoir, do not operate the pump. Check all diaphragms, then flush the reservoir completely (as outlined below) and refill it with fresh oil. Never let the pump stand with foreign material or water in the reservoir, or with the reservoir empty.
- e. Clean away any spilled oil. Apply Loctite #242 Threadlocker to threads of new diaphragm (17) (or old one).
- f. Install diaphragm (17) and tighten to 10 in-lbs (113 N-cm).
- g. Repeat above inspection procedure with other two diaphragms (17). Replace if necessary.

4. Flush Contaminant from Hydraulic End

(Only if diaphragm has ruptured)

- a. With valve plate and manifold still removed (see above), remove brass cap (60). Allow all oil and contaminant to drain out.
- b. Fill reservoir with kerosene or solvent, manually turn pump shaft to circulate kerosene, and drain. Dispose of contaminated fluid properly.

Caution: If you have EPDM diaphragms, or if food grade oil is in the reservoir, do not use kerosene or solvents. Instead, flush with the same lubricant that is in the reservoir.
- c. Repeat step b flushing procedure.
- d. Fill reservoir with fresh oil and manually turn pump shaft to circulate oil. Drain oil.
- e. Refill reservoir with fresh oil. If oil appears milky, there is still contaminant in reservoir. Repeat steps c and d until oil appears clean.

5. Prime Hydraulic Cells

- a. With pump **horizontal**, fill reservoir with the correct Hydra oil for application.

Note: P Series replacement parts kits (complete kits and diaphragm kits) include the correct oil for each specific P Series pump configuration.
- b. All air in oil within hydraulic cell (behind diaphragm) must be forced out by turning shaft and pumping piston. A shaft rotator is included in the Wanner Tool Kit.

Turn shaft until **bubble-free** flow of oil comes from behind all diaphragms. Watch oil level in reservoir. If oil gets too low during priming air will be drawn into piston (inside hydraulic end). Air will cause pump to run rough and repriming will be necessary.
- c. Wipe excess oil from the diaphragm plate (18) and diaphragms (17).

6. Reinstall Valve Plate (12), Manifold (3)

- a. Reinstall valve plate (12), with valve assemblies installed as outlined above, onto diaphragm plate (18).

Tighten two socket-head capscrews (14) evenly and snugly to compress outer diaphragm beads and hold valve plate (12) in place.
- b. Reinstall the o-rings (4) on rear side of manifold (3). Use petroleum jelly or lubricating gel to hold them in place.
- c. Reinstall manifold (3) onto valve plate (12).
- d. Insert bolts (1) with washers (2), around edge of manifold (3), and alternately tighten opposite bolts until all are secure. Torque to 15 ft-lbs (20 N-m).
- e. Recheck all bolts for tightness and proper torque.

P200 Fluid End Parts List

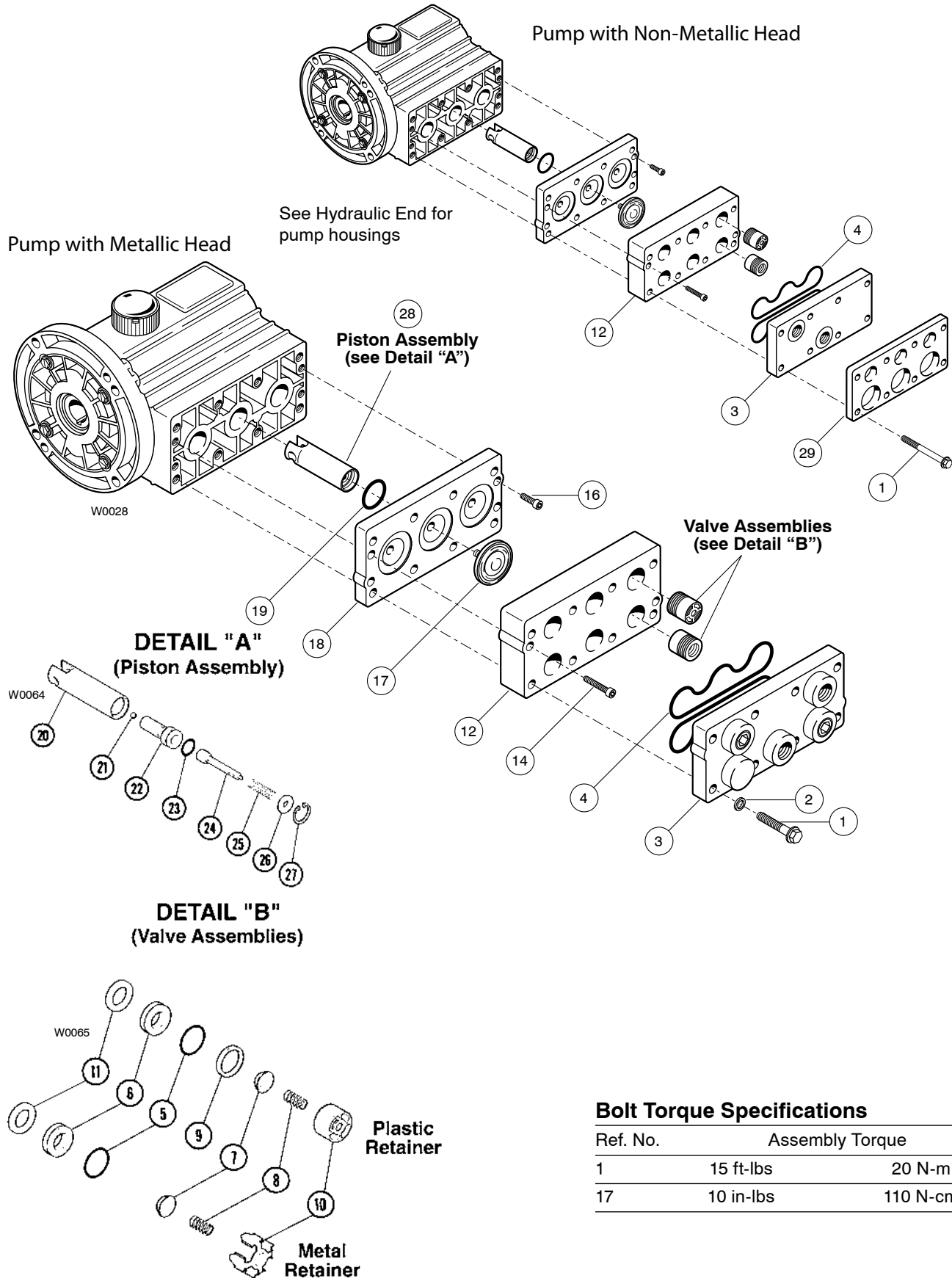

Bolt Torque Specifications

Ref. No.	Assembly Torque	
1	15 ft-lbs	20 N-m
17	10 in-lbs	110 N-cm

P200 Fluid End Parts List

Ref No.	Part Number	Description	Quantity/ Pump	Ref No.	Part Number	Description	Quantity/ Pump
1	D03-024-2010	Bolt, hex-head, 3" (for use with metallic head models)	8	10	D03-023-1017	Retainer, valve spring, Hastelloy C.....	6
	D03-024-2017	Bolt, hex-head, 4" (for use with non-metallic head models).....	8		D03-023-2317	Retainer, valve spring, polypropylene	6
					D03-023-2318	Retainer, valve spring, Kynar.....	6
2	C22-014-2000	Washer, 5/16" (metallic head only)	8	11	D03-125-1017	Washer, dampening, Hastelloy C	6
3	D03-004-1012	Manifold, 316 SST, NPT.....	1		D03-125-2317	Washer, dampening, polypropylene ...	6
	D03-004-1017	Manifold, nickel alloy (Hastelloy CW12MW), NPT.....	1		D03-125-2318	Washer, dampening, Kynar.....	6
	D03-004-1050	Manifold, polypropylene, NPT	1	12	D03-003-1012	Valve Plate, 316 SST	1
	D03-004-1053	Manifold, Kynar, NPT	1		D03-003-1027	Valve Plate, nickel alloy (Hastelloy CW12MW).....	1
	G13-004-1012	Manifold, 316 SST, BSPT	1		D03-003-1050	Valve Plate, polypropylene	1
	G13-004-1017	Manifold, nickel alloy (Hastelloy CW12MW), BSPT	1		D03-003-1053	Valve Plate, Kynar	1
	G13-004-1050	Manifold, polypropylene, BSPT	1	13	D25-038-2211	Plug, 316 SST, NPT	2
	G13-004-1053	Manifold, Kynar, BSPT.....	1		D25-038-2017	Plug, Hastelloy C, NPT	2
4	D25-073-2110	O-ring, manifold, Buna.....	2		G25-038-2211	Plug, 316 SST, BSPT	2
	D25-073-2111	O-ring, manifold, Viton	2		G25-038-2017	Plug, Hastelloy C, BSPT.....	2
	D25-073-2112	O-ring, manifold, Neoprene	2	14	D03-029-2010	Cap Screw, socket-head, 1"	2
	D25-073-2113	O-ring, manifold, EPDM	2	16	D03-088-2010	Cap Screw, socket-head, 3/4"	2
	D25-073-2118	O-ring, manifold, PTFE	2	17	D03-018-1212	Diaphragm, Neoprene.....	3
5	D25-046-2110	O-ring, valve seat, Buna	6		D03-018-1213	Diaphragm, EPDM	3
	D25-046-2111	O-ring, valve seat, Viton	6		D03-018-1215	Diaphragm, Viton-XT	3
	D03-035-2112	O-ring, valve seat Neoprene.....	6		D03-018-1220	Diaphragm, Buna-N-XS	3
	D03-035-2113	O-ring, valve seat, EPDM	6		D03-018-1218	Diaphragm, PTFE	3
	D03-035-2118	O-ring, valve seat, PTFE	6	18	D03-002-1000	Diaphragm Plate	1
6	D03-020-1001	Valve Seat, 316 SST	6	19	D03-075-2110	O-ring, diaphragm plate, Buna.....	3
	D03-020-1017	Valve Seat, Hastelloy C	6	20	D03-014-1004	Piston	3
	D03-020-3300	Valve Seat, ceramic	6	21	D10-015-3010	Ball	3
7	D03-021-1011	Valve, Nitronic 50	6	22	D03-043-1000	Valve Cylinder	3
	D03-021-1017	Valve, Hastelloy C.....	6	23	D03-034-2110	O-ring, valve cylinder, Buna.....	3
	D03-021-3300	Valve, ceramic.....	6	24	D03-044-1000	Valve Plunger	3
8	D03-022-3113	Valve Spring, Hastelloy C	6	25	D03-045-3110	Spring, sleeve valve	3
	D03-022-3114	Valve Spring, Elgiloy	6		D03-045-3111	Spring, sleeve valve for PTFE diaphragms	3
9	D03-092-2110	Tetra Seal, Buna	6	26	D03-049-1000	Washer	3
	D03-092-2111	Tetra Seal, Viton.....	6	27	D03-048-2210	Snap Ring.....	3
	D03-092-2112	Tetra Seal, Neoprene.....	6	28	D03-014-1210	Piston Assembly	3
	D03-092-2113	Tetra Seal, EPDM	6	29	D03-100-1010	Manifold Support Plate	1
	D03-035-2118	O-ring, PTFE.....	6				

P200 Hydraulic End Parts Lists

Ref No.	Part Number	Description	Quantity/ Pump
50	D03-086-2010	Cap Screw, hex-head, with washer	4
51	D25-047-2110	O-ring, back cover screws, Buna.....	4
52	D03-131-1000	Back Cover.....	1
53	D03-037-2110	O-ring, back cover, Buna	1
54	D03-031-2110	Seal, Buna.....	1
55	D03-011-2910	Back Bearing.....	1
57	M03-009-1003	(X) Hollow Shaft, 5/8" I.D.....	1
58	D03-133-1000	Pin	3
59	D03-132-1000	Connecting Rod	3
60	D10-078-2210	Cap, brass, 1/8" npt.....	1
61	D10-077-2210	Pipe, brass, 1/8" npt.....	1
62	D10-076-2210	Elbow, brass, 1/8" npt	1
63	D03-039-1030	Cap, oil fill (includes o-ring)	1
68	D03-010-2910	Front Bearing	1
78	D03-001-1033	Pump Housing.....	1
79	D10-040-2420	Name Plate.....	1

Hydraulic End Service

CAUTION: Do not disassemble or service the hydraulic end.

For assistance, contact Wanner Engineering at (612)332-5681 for the distributor in your area.

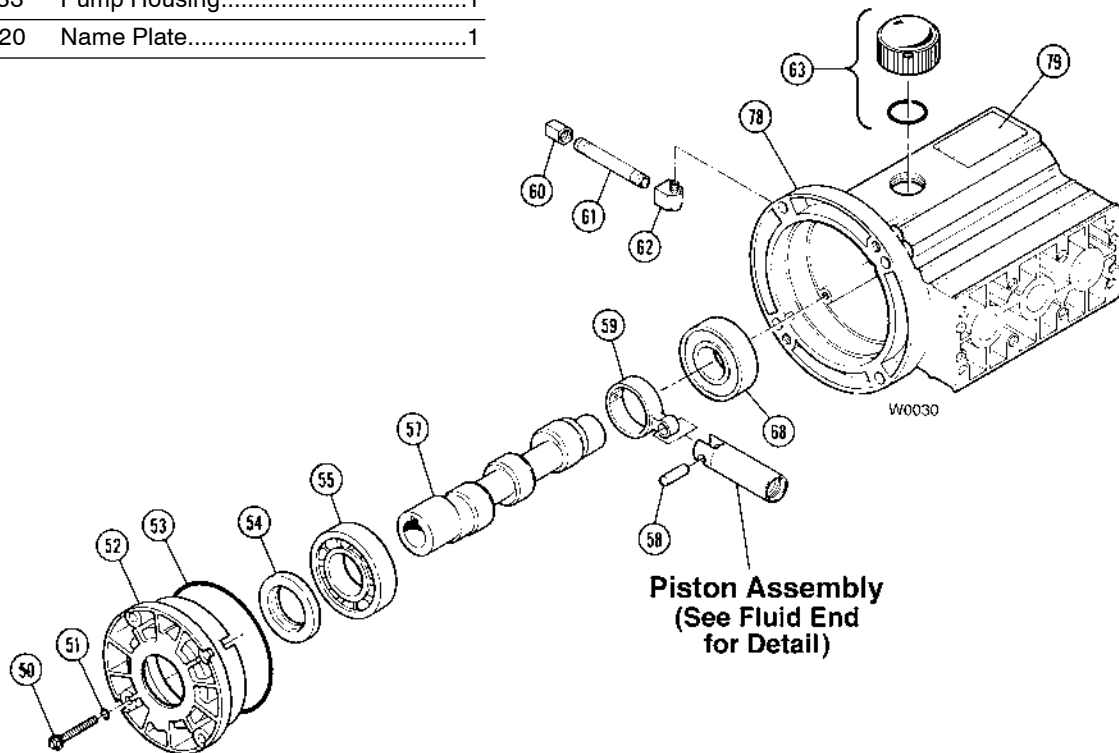

P200 Reducer/Base Assembly

Ref No.	Part Number	Description	Quantity/ Pump
100	112-100	Reducer, 5:1 ratio, 56C	1
	112-101	Reducer, 7.5:1 ratio, 56C	1
	112-102	Reducer, 10:1 ratio, 56C	1
	112-103	Reducer, 15:1 ratio, 56C	1
	112-104	Reducer, 20:1 ratio, 56C	1
	112-105	Reducer, 25:1 ratio, 56C	1
	112-106	Reducer, 30:1 ratio, 56C	1
	112-107	Reducer, 40:1 ratio, 56C	1
	112-108	Reducer, 50:1 ratio, 56C	1
	112-109	Reducer, 60:1 ratio, 56C	1
	112-110	Reducer, 80:1 ratio, 56C	1
	112-111	Reducer, 100:1 ratio, 56C	1
101	112-112	Kit, Protective Cover	1
102	112-113	Kit, Output Flange, FB	1
103	112-125	Kit, Single Output Shaft, EPM-P200	1
104	112-025	Kit, Single Output Shaft, EPM-P200	1
105	A04-024-1201	Assembly, M24 Coupling 5/8" x 5/8"	1
106	D03-100-1014	Adapter, P200	1
107	D03-026-2211	Dowel, Pin, 3/16" diameter	2
108	D03-101-2014	Screw, FHSCS, 5/16-18 X 1"	4
109	S1156-100	Washer, 0.312 flat	4

Ref No.	Part Number	Description	Quantity/ Pump
110	100-938	Lock Nut, 0.312-18	4
111	100-062	Screw, HHCS, 1/4-20 x 3/4"	3
112	100-663	Washer, 0.25 flat	6
113	100-063	Lock Nut, 1/4-20	3
114	S1256-020	Screw, HHCS, 3/8-16 UNC x 1.25"	4
115	D10-048-2010	Lock Washer, 3/8"	4
116	112-217	Metering Pump Base, Carbon Steel, painted	1
	112-218	Metering Pump Base, 304 SST	1

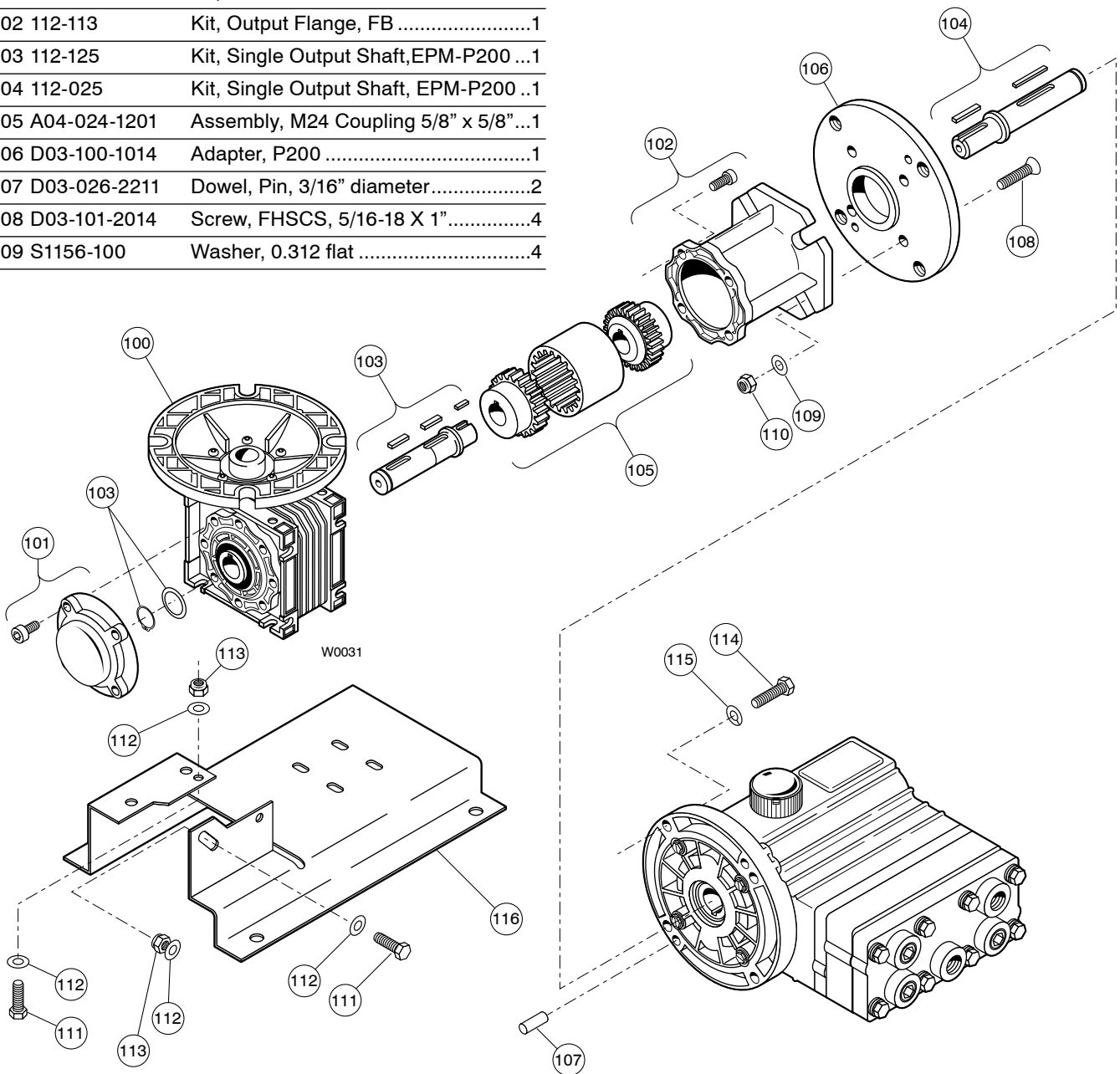

P200 Troubleshooting

Problem	Probable Cause	Solution
Motor/Pump Does Not Operate	No power.	Supply correct power according to motor requirements.
	Blown fuse/tripped circuit breaker.	Replace/reset, eliminate circuit overload.
	Shaft coupling to pump not in place.	Install proper coupling hardware (see parts list).
	Current overload - motor.	Motor not rated for pump operating conditions - install proper motor.
	Thermal overload - motor.	Motor not rated for pump and/or ambient operating conditions - supply cooling or install proper motor.
	Faulty motor drive/controller.	Repair/replace.
	Faulty motor.	Repair/replace.
	Low liquid level in supply tank (if low-level shut-off is used).	Fill tank.
No Delivery	Supply tank empty.	Fill tank.
	Inlet line or strainer clogged.	Clear debris and flush, or replace.
	Inadequate supply pressure at pump inlet.	Increase supply pressure by raising fluid level in tank, raising tank, or pressurizing suction tank.
	Inlet line too restrictive.	Increase inlet line diameter and/or decrease inlet line length.
	Fluid viscosity too high.	Reduce viscosity if possible (by heat or some other means). Increase inlet line diameter and/or decrease inlet line length. Increase supply pressure.
	Vapor lock/cavitation.	Increase inlet pressure. Decrease fluid temperature.
	Pump valves held open or worn out.	Clear debris and flush, or replace (see Fluid End Service)
	System relief valve actuating.	Adjust relief valve, or repair, clean, or replace with new relief valve.
Delivery Too Low and/or Erratic	Review all Probable Causes and Solutions in Problem 2 No Delivery above.	
	Air leak(s) in inlet line.	Locate all leaks and repair.
	System back pressure too low.	Adjust back pressure valve to higher setting. Install back pressure valve if none in system.
	Pumped fluid characteristics changed.	Monitor supply tank temperature to determine if fluid is too hot (leading to cavitation) or too cold (increasing fluid viscosity). Stabilize temperature at suitable level to resolve problem. Check for entrapped air in the fluid supply system.
	Inlet supply pressure changed.	Monitor inlet supply pressure (at the pump) to determine if it is too low, causing a starved condition/cavitation. Stabilize pressure at suitable level to resolve problem.
	Pump OK - Calibration system or flow meter error.	Evaluate components and repair/correct problem(s).
	Oil condition in pump hydraulic end changed.	Check oil level - if low evaluate for source of leakage. Consult factory for hydraulic end service.
		Change oil per recommended guidelines in maintenance section.
Delivery Too High and/or Erratic	System back pressure too low.	Adjust back pressure valve to higher setting. Install back pressure valve if none in system.
	Inlet supply pressure changed.	Monitor inlet supply pressure (at the pump) to determine if it is too high, causing a "flow-through" condition. Stabilize pressure at suitable level to resolve problem.
	Pump OK - Calibration system or flow meter error.	Evaluate components and repair/correct problem(s).

P200 Replacement Parts Kits

TO ORDER REPLACEMENT PARTS KIT: A Replacement Parts Kit contains 9 digits corresponding to customer-specified design options.

1	2	3	4	5	6	7	8	9
---	---	---	---	---	---	---	---	---

Digit	Order Code	Description
1-2		Pump Configuration
	P2	For all P200 Pumps
3		Kit Designator
	K	Complete Fluid End Kit*
	D	Diaphragm Kit*
	V	Valve Kit
4-5		Pump Head Version
	51	Standard
6		Spring Retainers/Dampening Washers
	M	For Kynar® pump head
	P	For Polypropylene pump head
	S	For 316 Stainless Steel pump head
	T	For Hastelloy® C pump head
	X	Not included in Diaphragm Kit
7		Diaphragm & O-ring Material
	E	EPDM
	G	Viton®-XT
	J	PTFE
	T	Buna-N-XS
8-9		Check Valve Material (Valve Spring / Valve & Seat)
	SS	316 SST / 316 SST
	TT	Hastelloy® C / Hastelloy® C
	SC	316 SST / Ceramic
	TC	Hastelloy® C / Ceramic
	XX	Not included in Diaphragm Kit

* Includes Hydraulic End Oil

Kit Contents

Part Number*	Description	Qty	Kit Designator		
			K	D	V
D03-018-___	Diaphragm	3	•	•	
D25-073-___	O-ring, manifold	2	•	•	•
D03-035-___ or					
D25-046-___	O-ring, valve seat**	6	•		•
D03-020-___	Valve seat	6	•		•
D03-021-___	Valve	6	•		•
D03-022-___	Valve spring	6	•		•
D03-092-___	Tetra seal***	6	•		•
D03-023-___	Retainer, valve spring	6	•		•
D03-125-___	Washer, dampening	6	•		•
A01-113-3400	Threadlocker	1	•		•
	Hydraulic End Oil	(1.5 qt)	•		•

* Last four digits of part numbers with -___ refer to specific material of construction.

** D03-035 is provided for EPDM, PTFE or Neoprene Diaphragm and O-rings; D25--046 is provided for Viton-XT or Buna-N-XS Diaphragm and O-rings.

***Not included with metal spring retainers.

Limited Warranty

Wanner Engineering, Inc. extends to the original purchaser of equipment manufactured by it and bearing its name, a limited one-year warranty from the date of purchase against defects in material or workmanship, provided that the equipment is installed and operated in accordance with the recommendations and instructions of Wanner Engineering, Inc. Wanner Engineering, Inc. will repair or replace, at its option, defective parts without charge if such parts are returned with transportation charges prepaid to Wanner Engineering, Inc., 1204 Chestnut Avenue, Minneapolis, Minnesota 55403.

This warranty does not cover:

1. The electric motors (if any), which are covered by the separate warranties of the manufacturers of these components.
2. Normal wear and/or damage caused by or related to abrasion, corrosion, abuse, negligence, accident, faulty installation or tampering in a manner which impairs normal operation.
3. Transportation costs.

This limited warranty is exclusive, and is in lieu of any other warranties (express or implied) including warranty of merchantability or warranty of fitness for a particular purpose and of any non-contractual liabilities including product liabilities based on negligence or strict liability. Every form of liability for direct, special, incidental or consequential damages or loss is expressly excluded and denied.

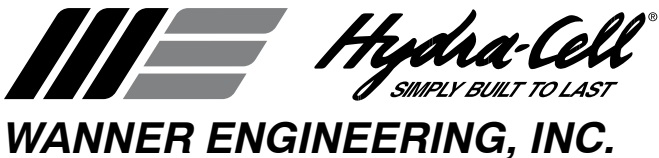

1204 Chestnut Avenue, Minneapolis, MN 55403
TEL: (612) 332-5681 FAX: (612) 332-6937
TOLL-FREE FAX [US only]: (800) 332-6812

www.epmpump.com
email: sales@wannereng.com